

A SAW-Stabilized FSK Oscillator

United States Patent Number 5793261

While a Colpitts oscillator circuit and a one-port SAW resonator can easily be combined to make a SAW-stabilized oscillator, getting an FSK version of this simple combination is not a trivial matter. One of the main advantages to the basic circuit, the frequency control dominance of the SAW element, presents a serious challenge in the FSK application. The circuit is under such tight control of the SAW resonator that it is very difficult to make it shift in frequency. If, somehow, the resonator is uncoupled from the circuit so as to make frequency deviation easier, frequency stability is sacrificed.

One of the original attempts at FSKing the basic Colpitts oscillator used a varactor diode in the collector tuned circuit (see Figure 1). This method works well in an oscillator circuit which is not frequency-stabilized by a resonator. The presence of a resonator makes deviation of the frequency more difficult. In addition, the ease with which the frequency of this circuit may be deviated is related to the insertion loss of the resonator. The lower the loss, the tighter the resonator control over the frequency of the oscillator circuit. As a result, there may be some unpredictable deviation results with this approach; sometimes there is deviation and sometimes there is not. The circuit can usually be made to work at lower frequencies (less than 300 MHz) if the collector is tuned with a variable capacitor, but results can not be guaranteed using fixed tuning elements. As this technique is applied at higher frequencies, results become more unpredictable and less manufacturable.

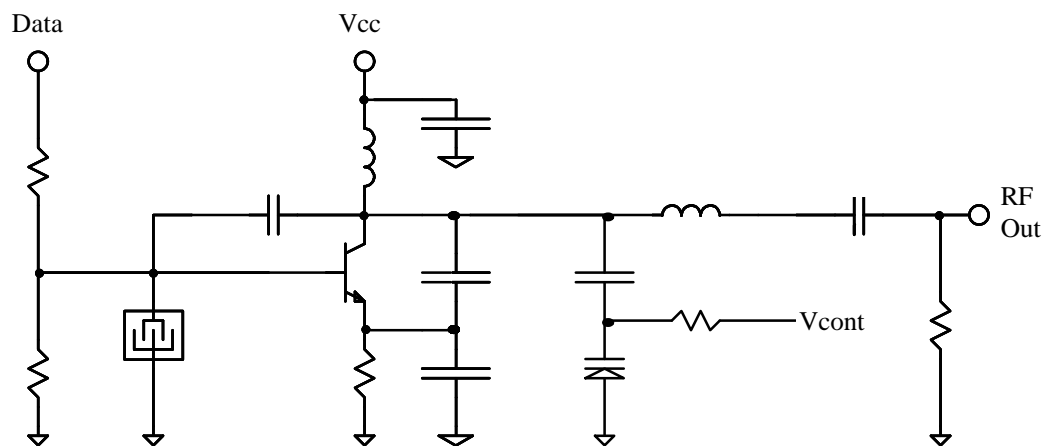

Figure 1

One way to deviate the frequency of a resonator-controlled oscillator is to insert capacitance in series with the SAW resonator. This changes the effective resonator frequency upward in a non-linear fashion; the smaller the capacitance, the higher the apparent resonant frequency. To achieve a sizable deviation, a very large min/max capacitance ratio is necessary - much larger than can be obtained with a varactor. Since the circuit is frequency stable with no series element at all, switching a series capacitance in or out would yield the desired result.

A circuit element which embodies all the required prerequisites is a simple transistor (see Figure 2). When the transistor is forward biased, it presents a low impedance, effectively grounding one end of the resonator. When biased off, the effective capacitance in series with the resonator is just that of the reversed-biased upper junction. This capacitance value depends on the type of transistor used, the direction in which it is installed, and the amount of reverse-bias voltage applied. The switching time, which ultimately determines the maximum FSK data rate, varies with the storage time of the transistor chosen. The reverse connection (as shown in Figure 2) exhibits shorter storage time than the forward connection for a given device.

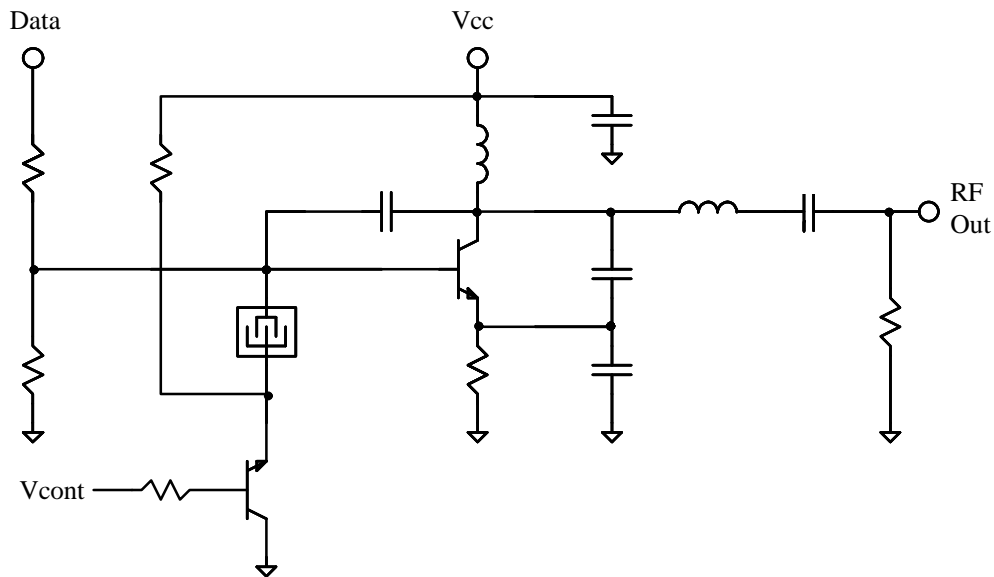

Figure 2

This patented circuit is available for license from RF Monolithics, Inc.