

# Type1MW Application Note

## Introduction

This Application Note targets HW developers.

It provides how to design the Schematic and Layout, and reference RF performance

For Module specification refer to “type1mw\_datasheet-\*”

Document Number: E2B-81-0932  
Version: 2.1  
Release Date: 2019/10/28

Murata Manufacturing Co., Ltd.

## Revision History

Revision Number	Release Date	Comments
1.0	2018.Apr.16	1 <sup>st</sup> issue
2.0	2018.Dec.28	1.3 reference circuit: revised BOM list.  5. Throughput performance: Added test environment of throughput test
2.1	2019.Oct.28	1.1 Type1MW Introduction:Updated BT ver(4.2 to 5.0) 4.2.1 BT current consumption:corrected condition(VIO=3.3V->1.8V)

**TABLE OF CONTENTS**

1	Module introduction .....	4
1.1	Type1MW Introduction.....	4
1.2	Block Diagram.....	4
1.3	Reference Circuit .....	5
2	HW Design Guideline .....	7
2.1	Underneath of module .....	7
2.2	Antenna.....	8
2.3	VBAT/CBUCK line.....	9
3.	RF Measurement Result.....	11
3.1	Tx output power level (at module antenna port).....	11
3.1.1.	WiFi .....	11
3.1.2.	Bluetooth .....	13
3.2	Rx minimum sensitivity level (at module antenna port).....	13
3.2.1.	WiFi .....	13
3.2.2.	Bluetooth .....	14
4.	Current consumption .....	15
4.1	WiFi.....	15
4.1.1.	Tx/Rx current consumption.....	15
4.1.2.	Sleep current consumption .....	16
4.2	Bluetooth.....	16
4.2.1.	BLE current consumption .....	16
5.	Throughput performance .....	17
	Test Environment .....	17
	Type1MW Configuration .....	17
	Test Result .....	17

## 1 Module introduction

### 1.1 Type1MW Introduction

- WLAN(11a/b/g/n/ac)+BT/BLE(BT5.0) combo SIP module with Cypress CYW43455
- The package type is LGA(SM type)
- This module is covered with resin molding and fully shielded with metal
- MAC and BD address are embedded in OTP

### 1.2 Block Diagram

Figure-1 shows module internal block diagram.

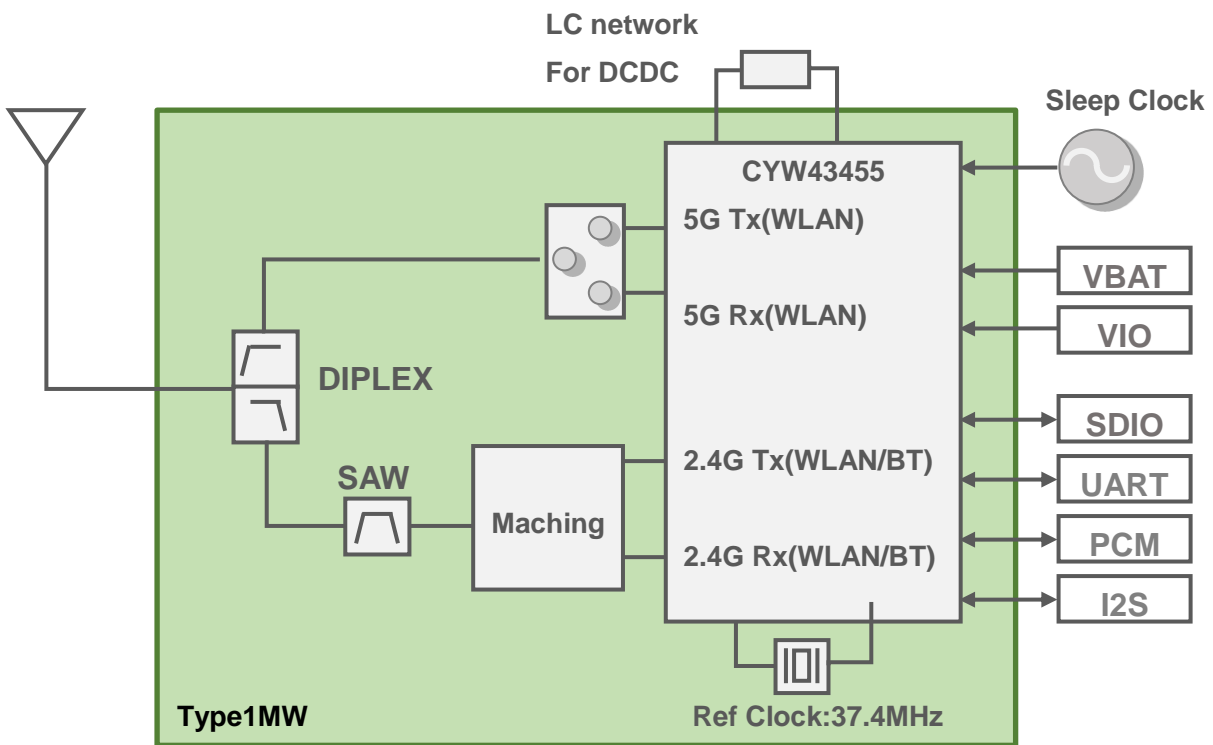

Figure-1, Block diagram

## 1.3 Reference Circuit

Figure-2 shows the reference circuit of Type1MW module.

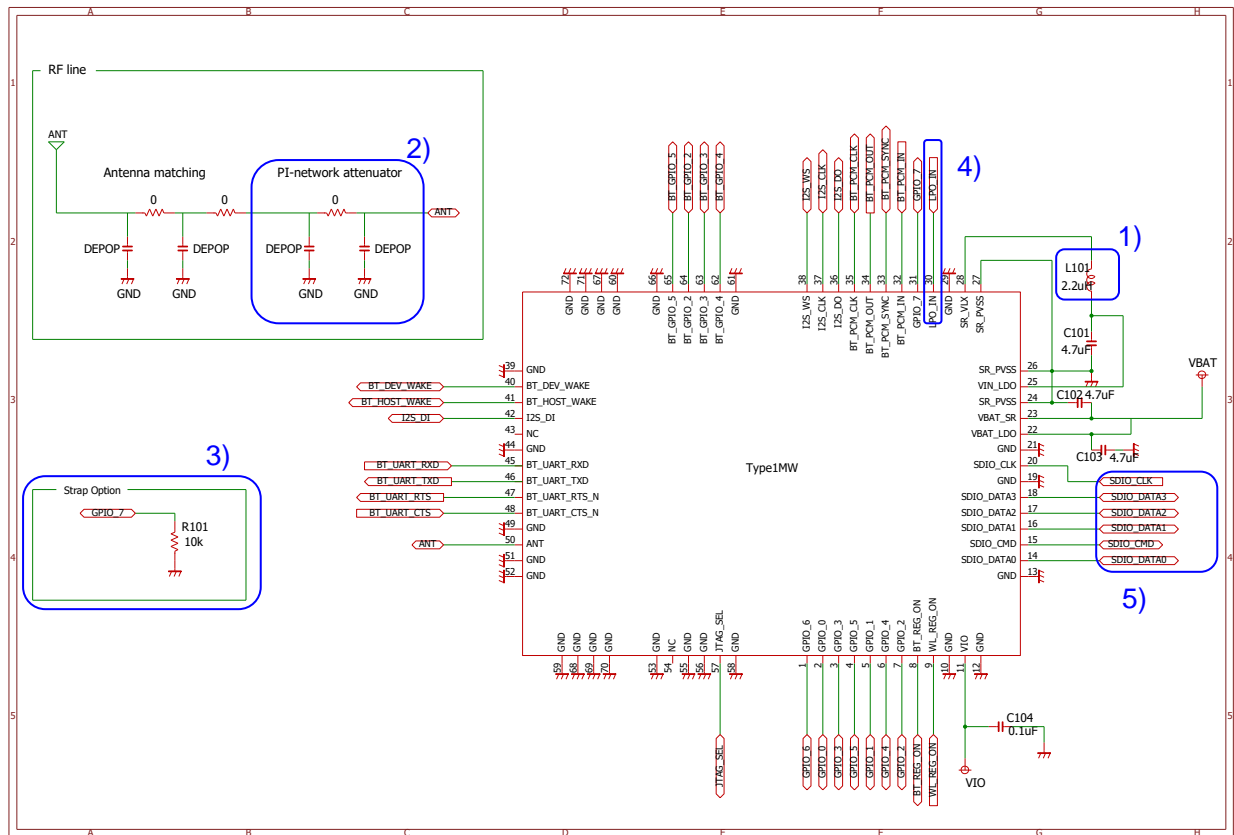

Figure-2, Reference Circuit

### 1) BOM list(Recommended P/N)

2.2uH:LQM18PN2R2M

### 2) Attenuator circuit

Please add attenuator circuit between Type1MW and antenna matching if you use Murata Radio certification. If your antenna peak gain is higher than Murata application one, please reduce antenna gain by this pi-type attenuator.

### 3) Strap Option of SDIO interface voltage

R101: Open SDIO interface voltage=1.8V

R101: 10kohm PD SDIO interface voltage=3.3V

#### 4) External 32.768kHz Sleep Clock Specifications

Table-1 shows External 32.768 kHz Low-Power Oscillator characteristics for Type1MW.

Table-1, External 32.768kHz Sleep Clock Specifications

Parameter	External LPO Clock	Unit
Nominal input frequency	32.768	kHz
Frequency accuracy	+/-200	ppm
Duty cycle	30-70	%
Input signal amplitude	200 - 3300	mVp-p
Signal type	Square-wave or sine-wave	-
Input impedance <sup>*a)</sup>	> 100k	ohm
	< 5	pF
Clock jitter (during initial start-up)	<10,000	ppm

\*a) when power is applied or switch off.

#### 5) SDIO

Please arrange SDIO lines with 50ohm and put series-R, shunt-C parts to reject the noise if needed. 10k~100k ohm pull-ups are required on the four DATA lines and the COMD line. This requirement must be met during all operating states by using external pull-ups. This module doesn't have internal pull-ups on these lines. Please confirm the performance on your board.

## 2 HW Design Guideline

### 2.1 Underneath of module

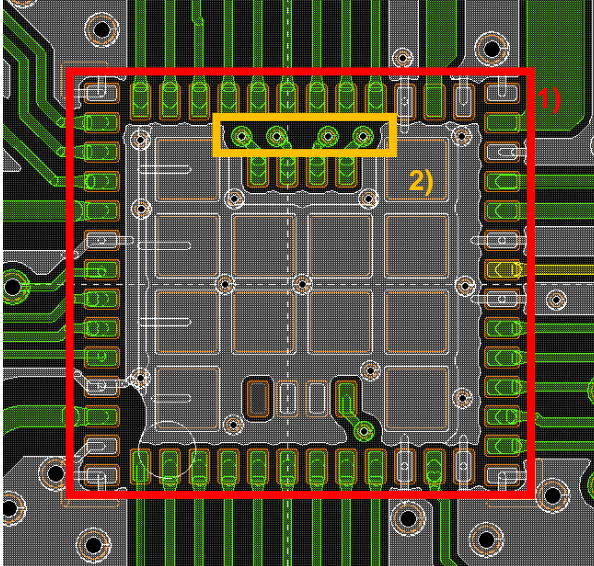

1) Please refer to Murata Datasheet regarding to Dimensions.

\*Murata is preparing DXF file that is module footprint. "Type1MW\_bottom layer\_Top view.dxf"

2) Via design between outside and inside module pad

Via Hole  $\Phi 150\mu\text{m}$

Via Land  $\Phi 350\mu\text{m}$

## 2.2 Antenna

Antenna line should be 50ohm (\*). There should be enough GND via along with Antenna line. Make sure that pi matching circuit is located right before the wifi antenna on the main board.

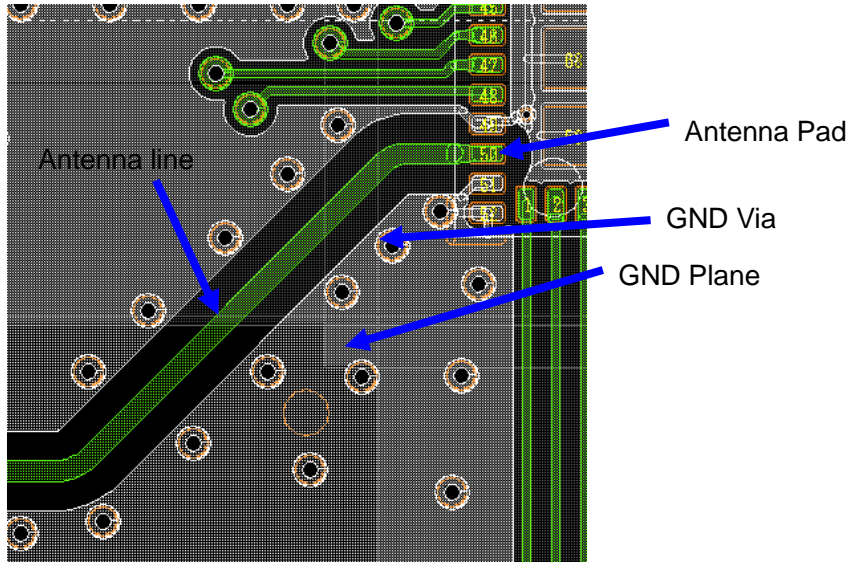

(\*) How to make 50ohm line?

[http://www17.plala.or.jp/i-lab/index\\_e.htm](http://www17.plala.or.jp/i-lab/index_e.htm)

Here are the conditions of 50ohm lines of evaluation board. (One of example)

- Epsilon : 4.3
- RF trace width(s) : 0.35mm
- GND gap(h) : 0.18mm
- GND gap(w) : 0.5mm

The line impedance is  $Z_0 = 51.8\text{ohm}$ .

**Coplanar Waveguide with Ground Calculator**

The screenshot shows a calculator interface for a Coplanar Waveguide with Ground. On the left, there is a diagram of a coplanar waveguide with a central signal line of width 'w', a gap of width 's', and another signal line of width 'w', all on a substrate of height 'h' and dielectric constant  $\epsilon_r$ . The calculator fields are as follows:

- $\epsilon_r$ : 4.3
- s: 0.35 [mm]
- h: 0.18 [mm]
- fo: 2400 [MHz]
- w: 0.5 [mm]
- Analyze button:  $Z_0 = 51.78151 [\Omega]$  (highlighted with a red box)
- Synthesis button:  $w$  [mm]
- $\epsilon_{eff}$ : 3.342490
- k: 0.546971
- $\lambda/4$ : 17.09286 [mm]



### 2.3 VBAT/CBUCK line

Make the line from SR\_VLX to VIN\_LDO as short as possible. C1:4.7uF capacitor should be as close to VIN\_LDO as possible.

If the main board is multilayer PCB type, it's better to separate the GND place for this area on the top later, then connect it to the main GND thru the via hole on the lower layer.

On VBAT\_SR line, C2:4.7uF bypass capacitor should be located as close to the module as possible. C2:4.7uF bypass capacitor should connect to SR\_PVSS.

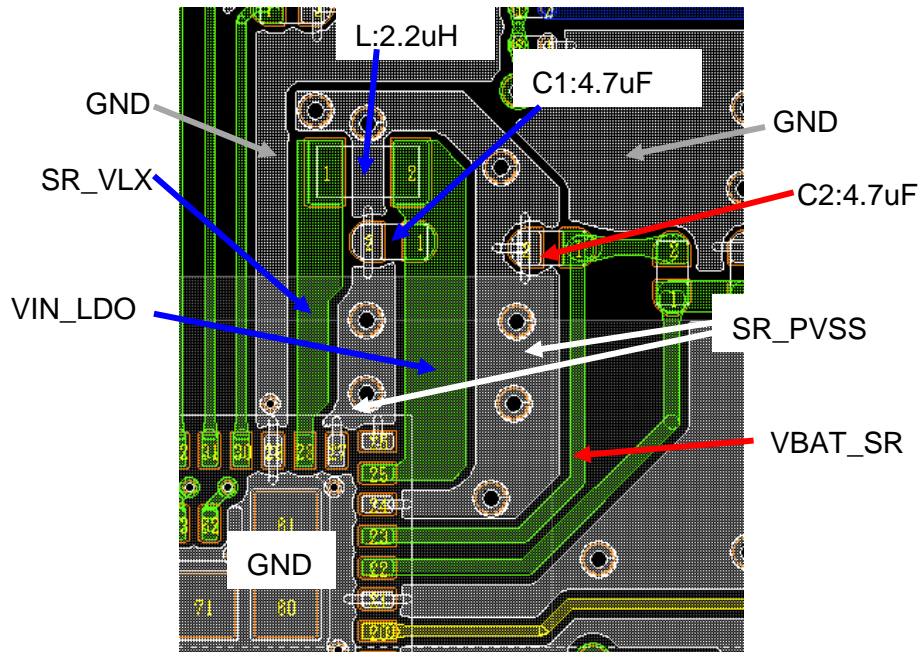

Layer1

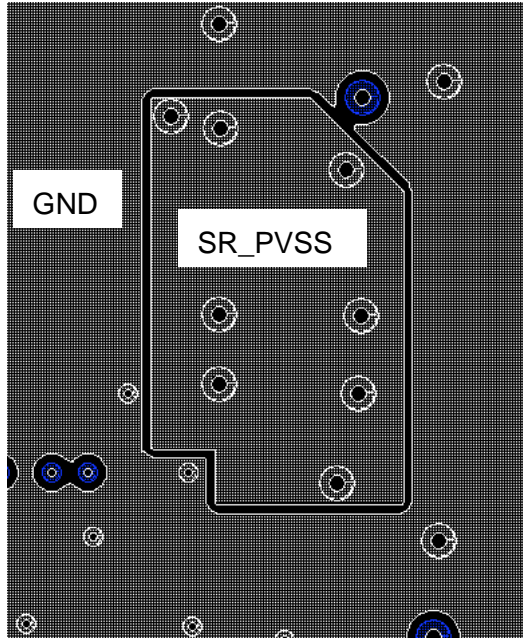

Layer2

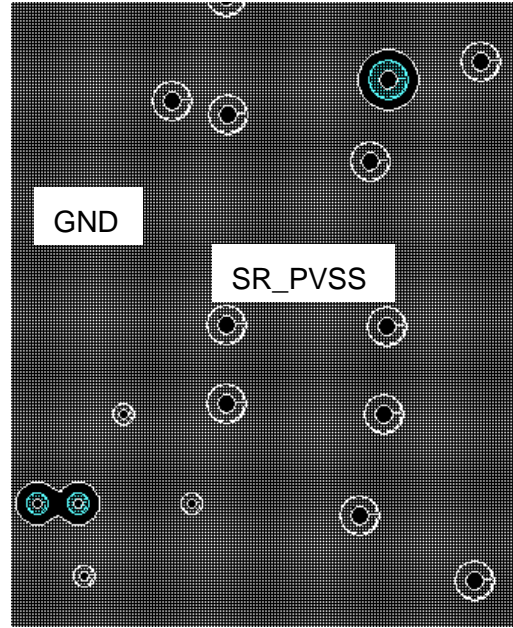

Layer3

### 3. RF Measurement Result

#### 3.1 Tx output power level (at module antenna port)

##### 3.1.1. WiFi

Tx output power setting is defined by Murata nvram file.

##### 2.4GHz

Mode	Data Rate	Output Power[dBm]
11b	1M	17.0
	2M	17.0
	5.5M	17.0
	11M	17.0
11g	6M	16.0
	9M	16.0
	12M	16.0
	18M	16.0
	24M	16.0
	36M	13.0
	48M	13.0
	54M	13.0
11n	MCS0	14.0
	MCS1	14.0
	MCS2	14.0
	MCS3	14.0
	MCS4	14.0
	MCS5	12.0
	MCS6	12.0
	MCS7	12.0

5GHz

Mode	Data Rate	Output Power[dBm]	Mode	Data Rate	Output Power[dBm]
11a	6M	15.0	11n HT40	MCS0	15.0
	9M	15.0		MCS1	15.0
	12M	15.0		MCS2	15.0
	18M	15.0		MCS3	15.0
	24M	15.0		MCS4	13.0
	36M	13.0		MCS5	13.0
	48M	13.0		MCS6	13.0
	54M	13.0		MCS7	13.0
11n HT20	MCS0	15.0	11ac VHT40	MCS0	15.0
	MCS1	15.0		MCS1	15.0
	MCS2	15.0		MCS2	15.0
	MCS3	15.0		MCS3	15.0
	MCS4	13.0		MCS4	13.0
	MCS5	13.0		MCS5	13.0
	MCS6	13.0		MCS6	13.0
	MCS7	13.0		MCS7	13.0
11ac VHT20	MCS0	15.0	11ac VHT20	MCS8	10.0
	MCS1	15.0		MCS9	10.0
	MCS2	15.0	11ac VHT80	MCS0	12.0
	MCS3	15.0		MCS1	12.0
	MCS4	13.0		MCS2	12.0
	MCS5	13.0		MCS3	12.0
	MCS6	13.0		MCS4	12.0
	MCS7	13.0		MCS5	10.0
	MCS8	13.0		MCS6	10.0
				MCS7	10.0
		MCS8	10.0		
		MCS9	10.0		

### 3.1.2. Bluetooth

<Condition>

- VBAT=3.3V, VIO=1.8V
- Hcd.file version : BCM4345C0\_003.001.025.0139.0234.hcd

Frequency[MHz]	Output Power [dBm]		
	DH5	3DH5	BLE
2402	6.3	1.5	4.9
2440	6.0	2.0	5.1
2480	5.2	0.9	4.1

### 3.2 Rx minimum sensitivity level (at module antenna port)

#### 3.2.1. WiFi

<Condition>

- VBAT=3.3V, VIO=1.8V
- FW version:version 7\_45\_86

#### 2.4GHz

Frequency[MHz]	Rx minimum sensitivity level[dBm]					
	11b		11g		11n	
	1Mbps	11Mbps	6Mbps	54Mbps	MCS0	MCS7
2412	-98.5	-89.3	-94.0	-76.8	-94.0	-75.0
2442	-98.8	-89.7	-94.1	-77.0	-94.1	-75.0
2472	-98.0	-88.8	-93.4	-76.3	-93.4	-74.4

#### 5GHz(20MHz band)

Frequency[MHz]	Rx minimum sensitivity level[dBm]					
	11a		11n(HT20)		11ac(VHT20)	
	6Mbps	54Mbps	MCS0	MCS7	MCS0	MCS8
5180	-93.2	-76.1	-93.2	-74.2	-93.1	-69.9
5500	-93.2	-76.1	-93.1	-74.1	-92.9	-69.9
5825	-93.4	-76.3	-93.3	-74.3	-93.1	-70.1

**5GHz(40MHz band)**

Frequency[MHz] ]	Rx minimum sensitivity level[dBm]			
	11n(HT40)		11ac(VHT40)	
	MCS0	MCS7	MCS0	MCS9
5190	-89.9	-70.4	-90.2	-65.2
5510	-90.1	-70.4	-90.4	-65.3
5795	-90.2	-70.5	-90.6	-65.5

**5GHz(80MHz band)**

Frequency[MHz] ]	Rx minimum sensitivity level[dBm]	
	11ac(VHT80)	
	MCS0	MCS9
5210	-87.5	-62.5
5530	-87.8	-62.6
5775	-87.7	-62.6

**3.2.2. Bluetooth**

<Condition>

- VBAT=3.3V, VIO=1.8V
- Hcd.file version : BCM4345C0\_003.001.025.0139.0234.hcd

Frequency[MHz]	Rx minimum sensitivity level[dBm]		
	DH5	3DH5	BLE
2402	-91.0	-90.1	-95.5
2440	-91.9	-91.3	-95.5
2480	-90.6	-90.6	-95.1

## 4. Current consumption

### 4.1 WiFi

#### 4.1.1. Tx/Rx current consumption

<Condition>

- VBAT=3.3V, VIO=1.8V
- WL\_REG\_ON:ON, BT\_REG\_ON:ON
- FW version:version 7\_45\_86
- Setting value:1024byte, 20usec interval

#### 2.4GHz

Mode	Rate	Tx current		Rx current[mA]*b)
		setting power	Tx current[mA]*a)	
11b	1Mbps	17	324	58
11g	6Mbps	16	331	58
11n	MCS0	14	304	58

\*a) Setting value:1024byte, 20usec interval

\*b) Carrier sense when no carrier present.

#### 5GHz

Mode	Rate	Tx current		Rx current[mA]*b)
		setting power	Tx current[mA]*a)	
11a	6Mbps	15	301	75
11n(HT40)	MCS0	15	320	85
11ac(VHT80)	MCS0	12	328	110

\*a) Setting value:1024byte, 20usec interval

\*b) Carrier sense when no carrier present.

#### 4.1.2. Sleep current consumption

<Condition>

- VBAT=3.3V, VIO=1.8V
- WL\_REG\_ON:ON, BT\_REG\_ON:OFF
- FW\_version: 7.45.59.4

Band	Mode	VBAT(3.3V) mA	VDDIO(1.8V) uA
-	IEEE Power save, Inter Beacon*a)	0.09	180
2.4GHz	IEEE Power Save:DTIM1*b)	1.77	180
	IEEE Power Save:DTIM3	0.62	180
	IEEE Power Save:DTIM5	0.43	180
5GHz	IEEE Power Save:DTIM1	0.91	180
	IEEE Power Save:DTIM3	0.40	180
	IEEE Power Save:DTIM5	0.30	180

\*a). Idle, not associated, or inter-beacon.

\*b). Beacon Interval = 100ms

## 4.2 Bluetooth

#### 4.2.1. BLE current consumption

<Condition>

- VBAT=3.3V, VIO=1.8V
- WL\_REG\_ON:OFF, BT\_REG\_ON:ON
- Hcd.file version: BCM4345C0\_003.001.025.0139.0234.hcd

Mode	VBAT(3.3V)	VDDIO(1.8V)
	uA	uA
BLE Scan *a)	213	155
BLE Adv-Uncounnectable 1.00sec	98	155
BLE connected 1sec	42	159

\*a) No devices present. A 1.28 second interval with a scan window of 11.25ms.



## 5. Throughput performance

### Test Environment

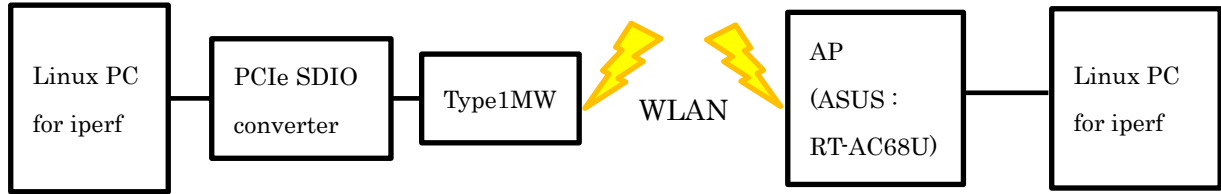

Throughput measurement tool : iperf

### Type1MW Configuration

- WLAN Driver version : 1.141.67.11
- FW version : 7.45.59.4
- NVRAM : bcm943455wlsagb\_Type1MW\_3.3v\_180112.txt
- VBAT=3.3V, VIO=1.8V
- WL\_REG\_ON:ON, BT\_REG\_ON:ON

### Test Result

#### 2.4GHz

11n_HT20_MCS7	Tx[Mbps]	Rx[Mbps]
TCP	58	69
UDP	59	83

#### 5GHz

11ac_VHT80_MCS9	Tx[Mbps]	Rx[Mbps]
TCP	229	263
UDP	310	349

(END)